

Mango1808 LCD Touch Test

<http://www.mangoboard.com/>

<http://cafe.naver.com/embeddedcrazyboys>

Crazy Embedded Laboratory

Document History

Revision	Date	Change note

목차

1.	Mango1808 LCD Touch Test.....	4
1.1.	Buildroot 컴파일 변경	4
1.2.	How To Fusing Filesystem.....	4
1.3.	Touch Test	6
1.4.	Hardware 변경.....	7

1. Mango1808 LCD Touch Test

www192.168.0.2/share/mango-1808/Source/mango1808_linux_mrvl8787_130103

1.1. Buildroot 컴파일 변경

buildroot 컴파일 toolchain 변경

```
$ make menuconfig
```

컴파일 toolchain 을 변경

```
Toolchain ---> Toolchain (Sourcery CodeBench ARM 2009q3) ---> (X) Sourcery CodeBench  
ARM 2009q3
```

1.2. How To Fusing Filesystem

```
$tar xf mango1808_linux_mrvl8787_130103_ETH_RTL8201_LED_image.tgz
```

```
$cd mango1808_linux_mrvl8787_130103_ETH_RTL8201_LED_image
```

```
$sudo ./sdwriter sdc 1808 gnome
```

위의 방법 으로 안될시에,

"mmc 8GB " Host PC 에 삽입한다.

```
#sudo dmesg | tail
```

```
[10993.575042] sd 7:0:0:0: [sdb] Assuming drive cache: write through
```

```
[10993.576432] sdb: sdb1 sdb2 sdb3 sdb4
```

```
[root@HP-note-jji image]# sudo fdisk /dev/sdb
```

```
Command (m for help): p
```

```
Disk /dev/sdb: 8010 MB, 8010072064 bytes
```

```
214 heads, 8 sectors/track, 9138 cylinders, total 15644672 sectors
```

```
Units = sectors of 1 * 512 = 512 bytes
```

```
Sector size (logical/physical): 512 bytes / 512 bytes
```

```
I/O size (minimum/optimal): 512 bytes / 512 bytes
```

```
Disk identifier: 0x00000000
```

Device	Boot	Start	End	Blocks	Id	System
/dev/sdb1		8192	15644671	7818240	b	W95 FAT32

Command (m for help): d

Selected partition 1

Command (m for help): n

Partition type:

p primary (0 primary, 0 extended, 4 free)

e extended

Select (default p): p

Partition number (1-4, default 1):

Using default value 1

First sector (2048-15644671, default 2048):

Using default value 2048

Last sector, +sectors or +size{K,M,G} (2048-15644671, default 15644671):

Using default value 15644671

Command (m for help): p

Disk /dev/sdb: 8010 MB, 8010072064 bytes

214 heads, 8 sectors/track, 9138 cylinders, total 15644672 sectors

Units = sectors of 1 * 512 = 512 bytes

Sector size (logical/physical): 512 bytes / 512 bytes

I/O size (minimum/optimal): 512 bytes / 512 bytes

Disk identifier: 0x00000000

Device	Boot	Start	End	Blocks	Id	System
/dev/sdb1		2048	15644671	7821312	83	Linux

Command (m for help): w

The partition table has been altered!

Calling ioctl() to re-read partition table.

Syncing disks.

[root@HP-note-jji image]# mkfs

mkfs	mkfs.ext2	mkfs.ext4dev	mkfs.ntfs
------	-----------	--------------	-----------

```
mkfs.bfs    mkfs.ext3    mkfs.minix  mkfs.vfat
mkfs.cramfs mkfs.ext4    mkfs.msdos
[root@HP-note-jji image]# mkfs.ext4 -help
mkfs.ext4: invalid option -- 'h'
Usage: mkfs.ext4 [-c|-l filename] [-b block-size] [-C cluster-size]
[-i bytes-per-inode] [-I inode-size] [-J journal-options]
[-G meta group size] [-N number-of-inodes]
[-m reserved-blocks-percentage] [-o creator-os]
[-g blocks-per-group] [-L volume-label] [-M last-mounted-directory]
[-O feature[,...]] [-r fs-revision] [-E extended-option[,...]]
[-T fs-type] [-U UUID] [-jnqvFKSV] device [blocks-count]
```

```
# mkfs.ext4 -L mango1808 /dev/sdb1

# sudo mkdir fs
# sudo mount /dev/sdb1 fs
# cd fs/
# sudo tar xf ../rootfs.tar
# cd ..
# sudo sync
# sudo umount /dev/sdb1
```

1.3. Touch Test

Mango1808 Board 에 MMC 카드를 삽입 후 부팅을 합니다.
Mango1808 board 에서 아래입력

```
export TSLIB_TSDEVICE=/dev/input/event1
export TSLIB_TSEVENTTYPE=INPUT
export TSLIB_CONFFILE=/etc/ts.conf
export TSLIB_CALIBFILE=/etc/pointercal
export QWS_MOUSE_PROTO="Tslib:/dev/input/event1 Auto"
```

```
# ts_calibrate
```

touch 되는 것을 확인 떨림 현상 있습니다.

1.4. Hardware 변경

V100, V101, V102, V103 변경

Varistor -> cap 10nF

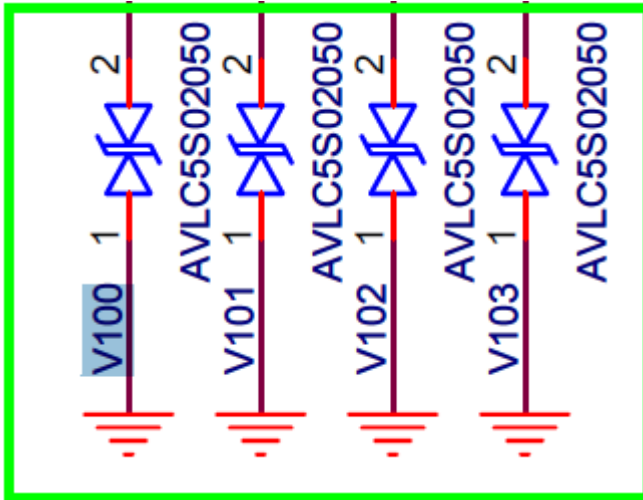

변경 후 떨림 없어짐